

BOYLAN HALL CAFETERIA SCREENS

SHOP DRAWINGS

MATERIAL SPECIFICATION:

MANUFACTURER

3form, Inc., Salt Lake City, Utah, USA / telephone 801-649-2500

MATERIAL

Varia™ produced from ecoresin™ Sheet, Engineered polyester resin, Thickness: 1"

Panel types used:

Type A: SOLO #SO-69410.3; Color "Bliss x1 (1) + Bliss x2 (2)"; Panel Finish Front "Sandstone" Back "Sandtsotne".
Type B: SOLO #SO-69410.1; Color "Sassy x1 (7)"; Panel Finish Front "Sandstone" Back "Sandtsotne".
Type C: SOLO #SO-69410.5; Color "Oj x1 (11) + Canary x1 (9)"; Panel Finish Front "Sandstone" Back "Sandtsotne".
Type D: SOLO #SO-69410.4; Color "Canary x2 (10)"; Panel Finish Front "Sandstone" Back "Sandtsotne".
Type E: SOLO #SO-69410.2; Color "Vapor x1 (45)"; Panel Finish Front "Patina" Back "Sandtsotne".

DRAWING SCHEDULE:

- 0.1 Title Sheet
- 1 Plan View - Boylan hall cafeteria.
- 2 Plan View -1, Elevation-A.
- 3 Plan View -2, Elevation-B.
- 4 Enlarged Plan View 1 & 2.
- 5 Elevation-Panel Layout.
- 6 Mounting Hardware Layout.
- 7 Details & 3 Form take-off sheet.

LEGEND:

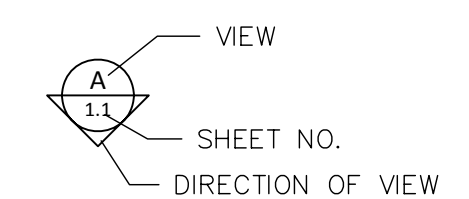

0.1

SHOP NOTES:

N&N Architectural Drafting Service
Computer Aided Design & Drafting/ CNC Programming

Drawn by: Neno K.

NO.	REVISION REASON	DATE
1	PANEL SUPPORT BASE PLATE	NOV-10

Project:
BOYLAN HALL CAFETERIA SCREENS

Date:
10-21-08

Job #

—

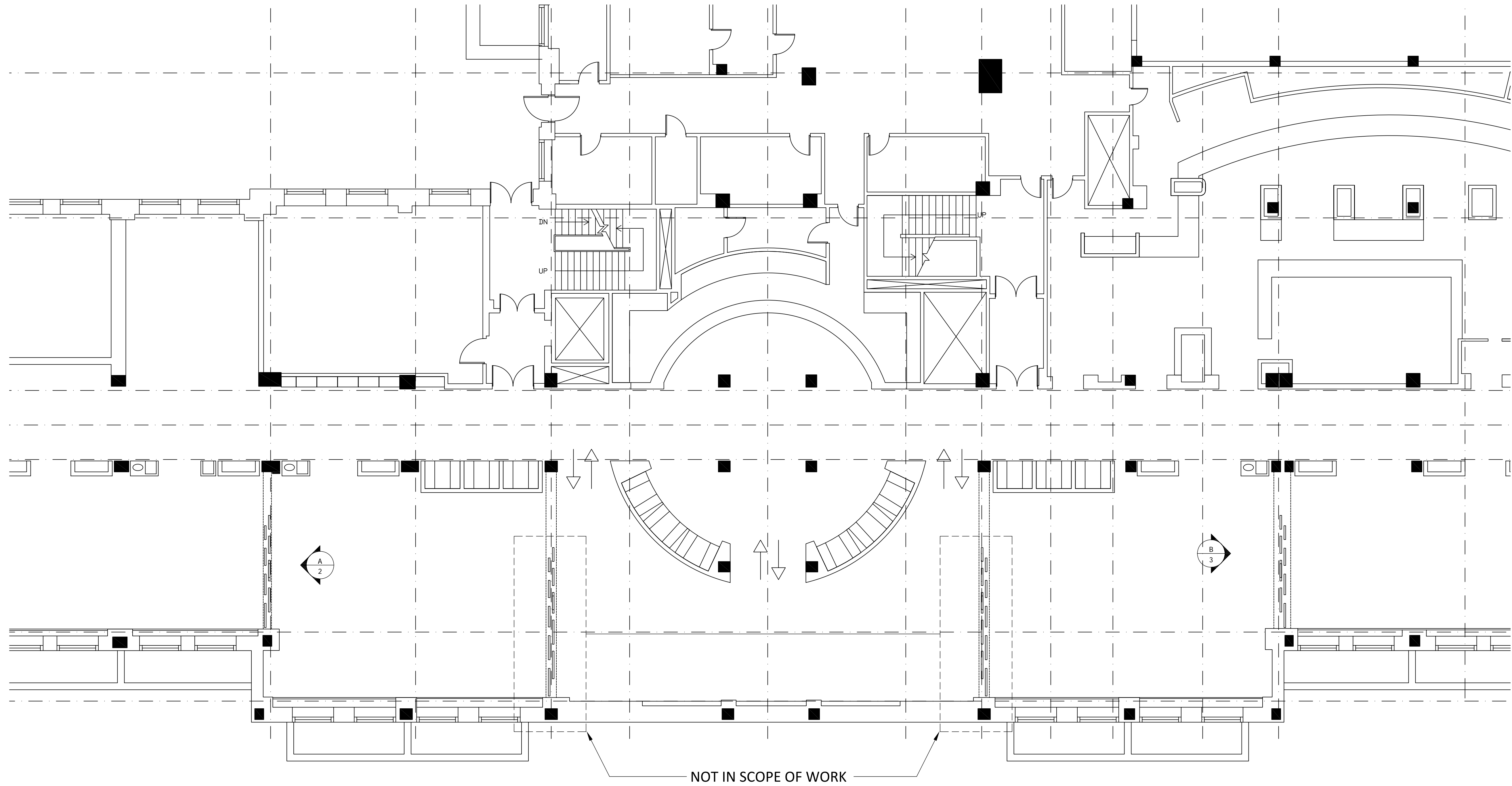

PLAN VIEW- BOYLAN HALL CAFETERIA
Scale: 1/8" = 12"

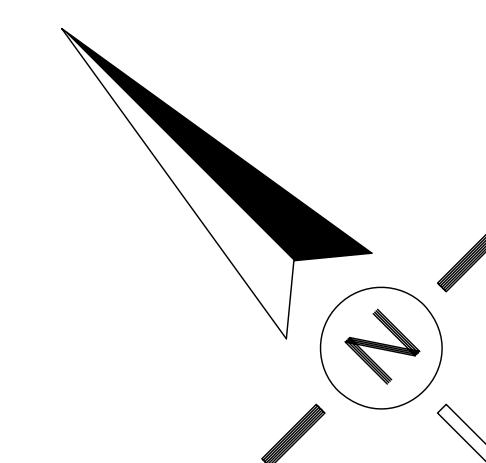

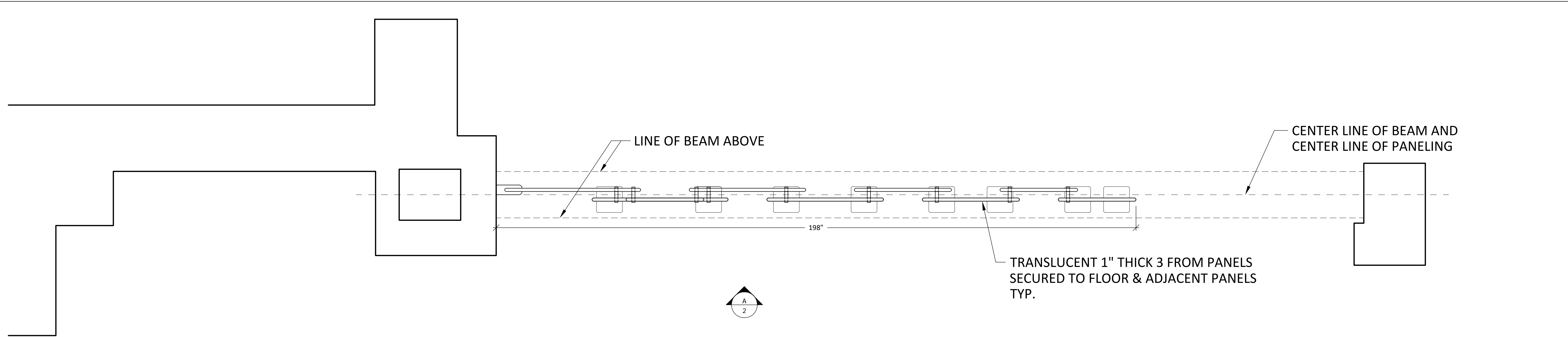

1 PLAN VIEW- 3 FORM SCREENS
Scale: 3/4" = 12"

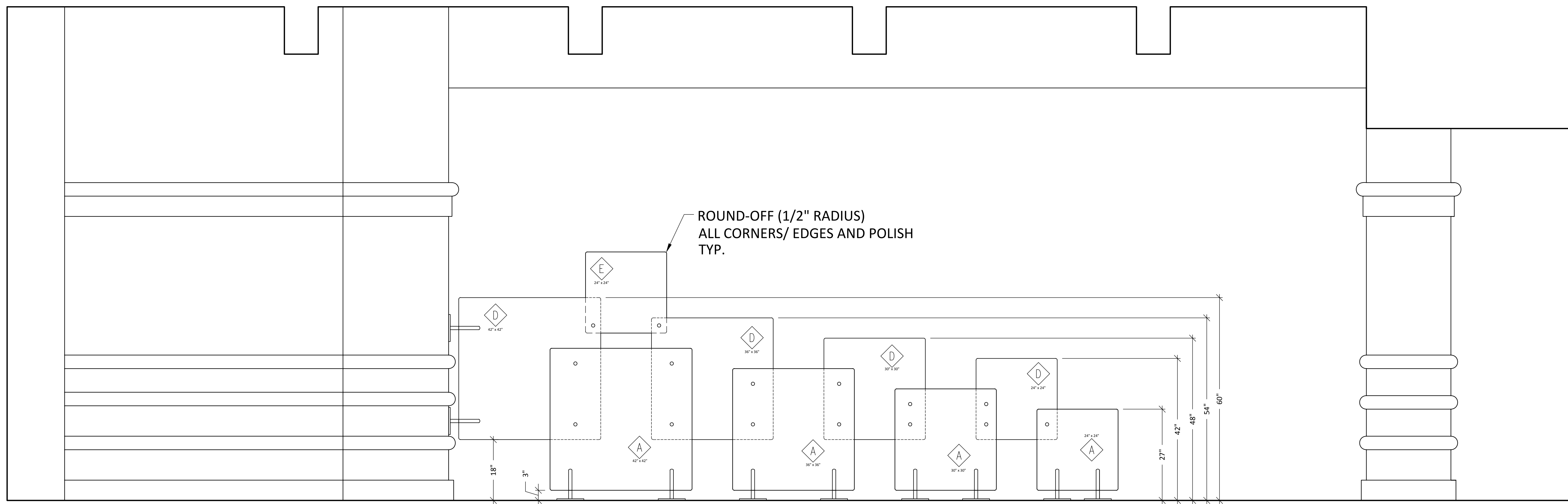

A ELEVATION-3 FORM SCREENS
Scale: 3/4" = 12"

N&N Architectural Drafting Service
Computer Aided Design & Drafting/ CNC Programming

Drawn by: Neno K.

NO.	REVISION/ REASON	DATE
	PANEL SUPPORT BASE PLATE	

Project:	BOYLAN HALL CAFETERIA SCREENS
Date:	10-21-08
Job #:	

SHOP NOTES:

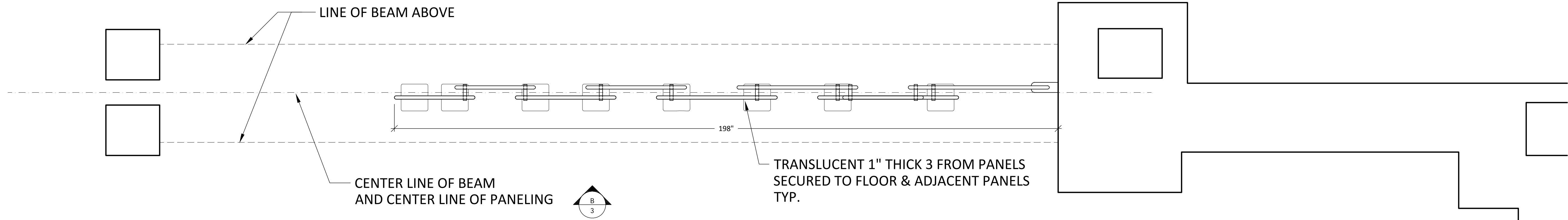

2 PLAN VIEW -3 FORM SCREENS
Scale: 3/4" = 12"

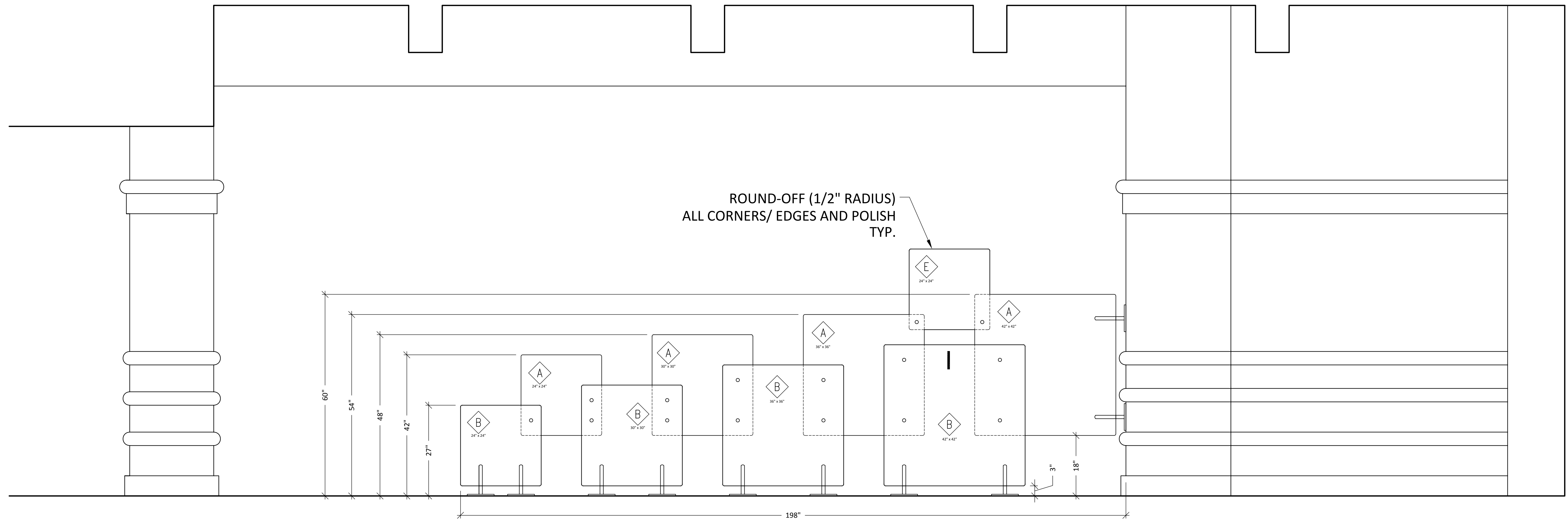

B ELEVATION-3 FORM SCREENS
Scale: 3/4" = 12"

N&N Architectural Drafting Service
Computer Aided Design & Drafting / CNC Programming

Drawn by: *Nemo K.*

NO.	REVISION / CHANGE	DATE
	PANEL SUPPORT BASE PLATE	REV. 01

Project: BOYLAN HALL CAFETERIA SCREENS
Date: 10-21-08
Job #

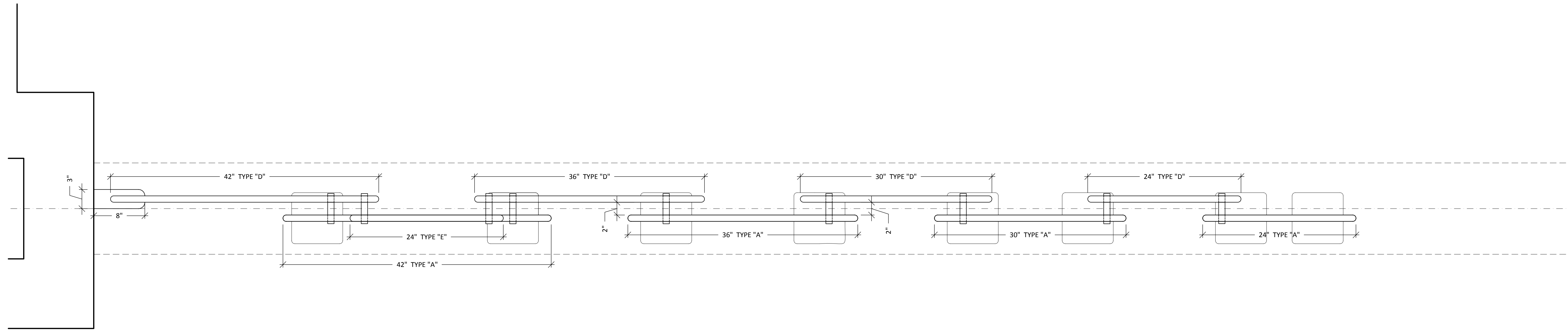

1 ENLARGED PLAN VIEW
Scale: 1 1/2" = 12"

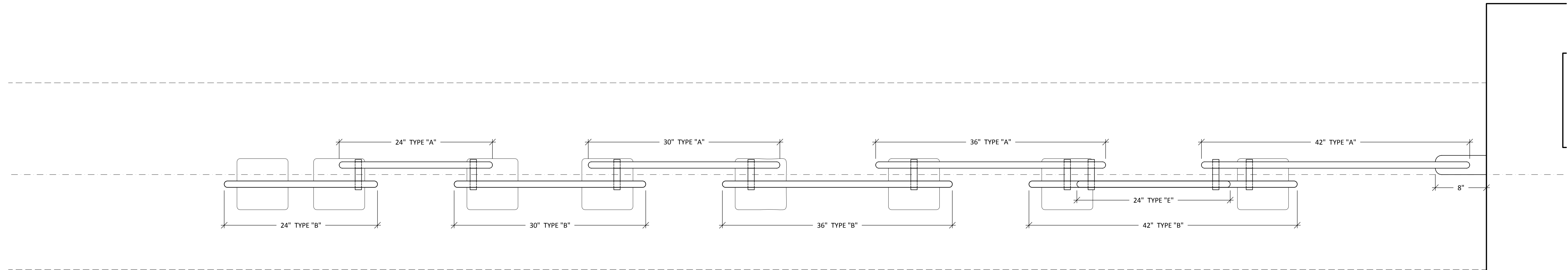

2 ENLARGED PLAN VIEW
Scale: 1 1/2" = 12"

SHOP NOTES:

N&N Architectural Drafting Service
Computer Aided Design & Drafting/ CNC Programming

Drawn by: Nemo K.

NO.	REVISION/ REASON	DATE
1	PANEL SUPPORT BASE PLATE	REV. 01

Project: BOYLAN HALL CAFETERIA SCREENS

Date: 10-21-08

Job #

SHOP NOTES:

N&N Architectural Drafting Service
Computer Aided Design & Drafting/ CNC Programming

Drawn by: *Nino K.*

NO:	REVISIONS:	DATE:
	PANEL SUPPORT BASE PLATE	NOV-10

Project: BOYLAN HALL CAFETERIA SCREENS

Date: 10-21-08

Job #

5

A/B PANEL LAYOUT
Scale: 1 1/2" = 12"
"B" ELEVATION IS MIRROR IMAGE

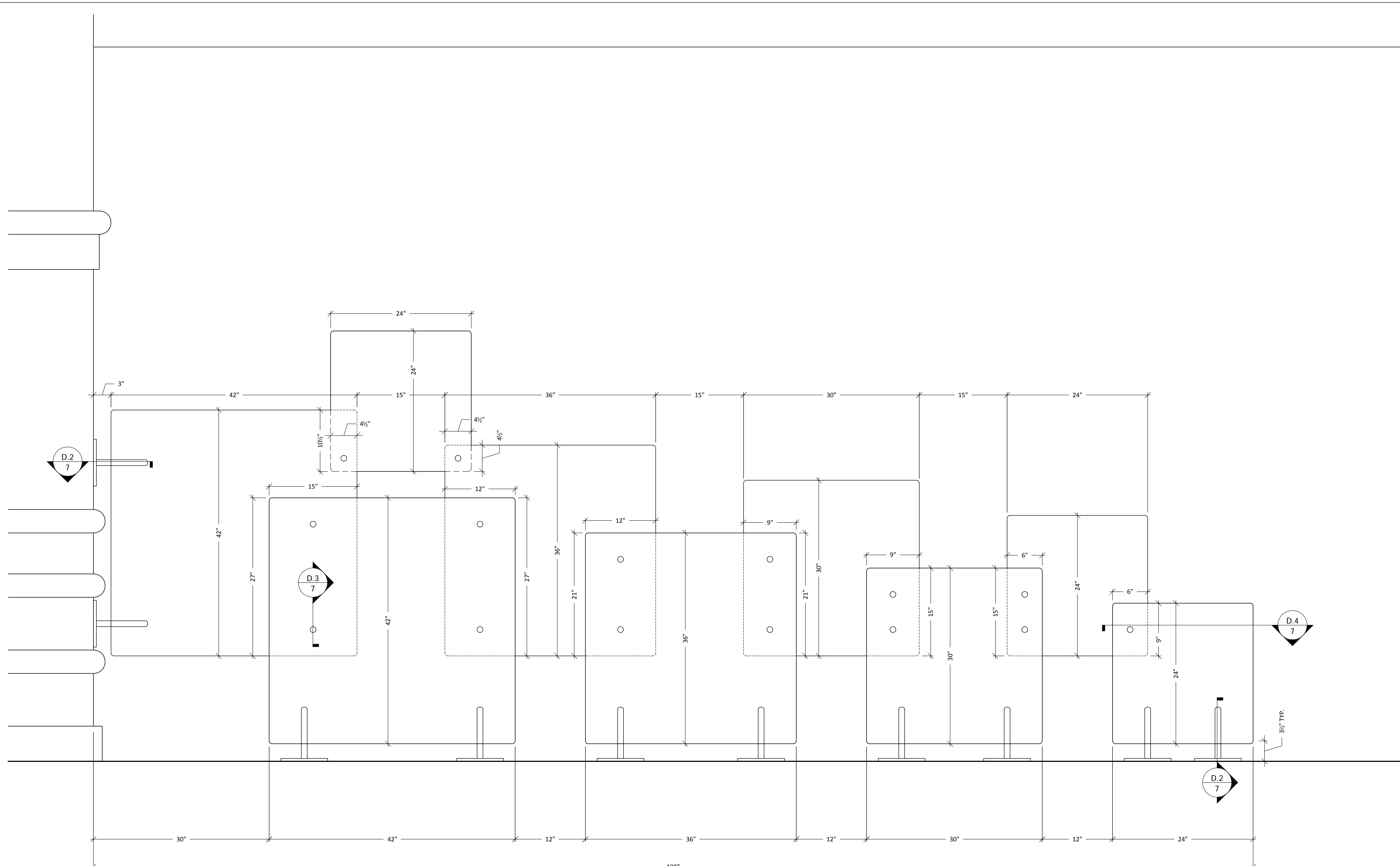

SHOP NOTES:

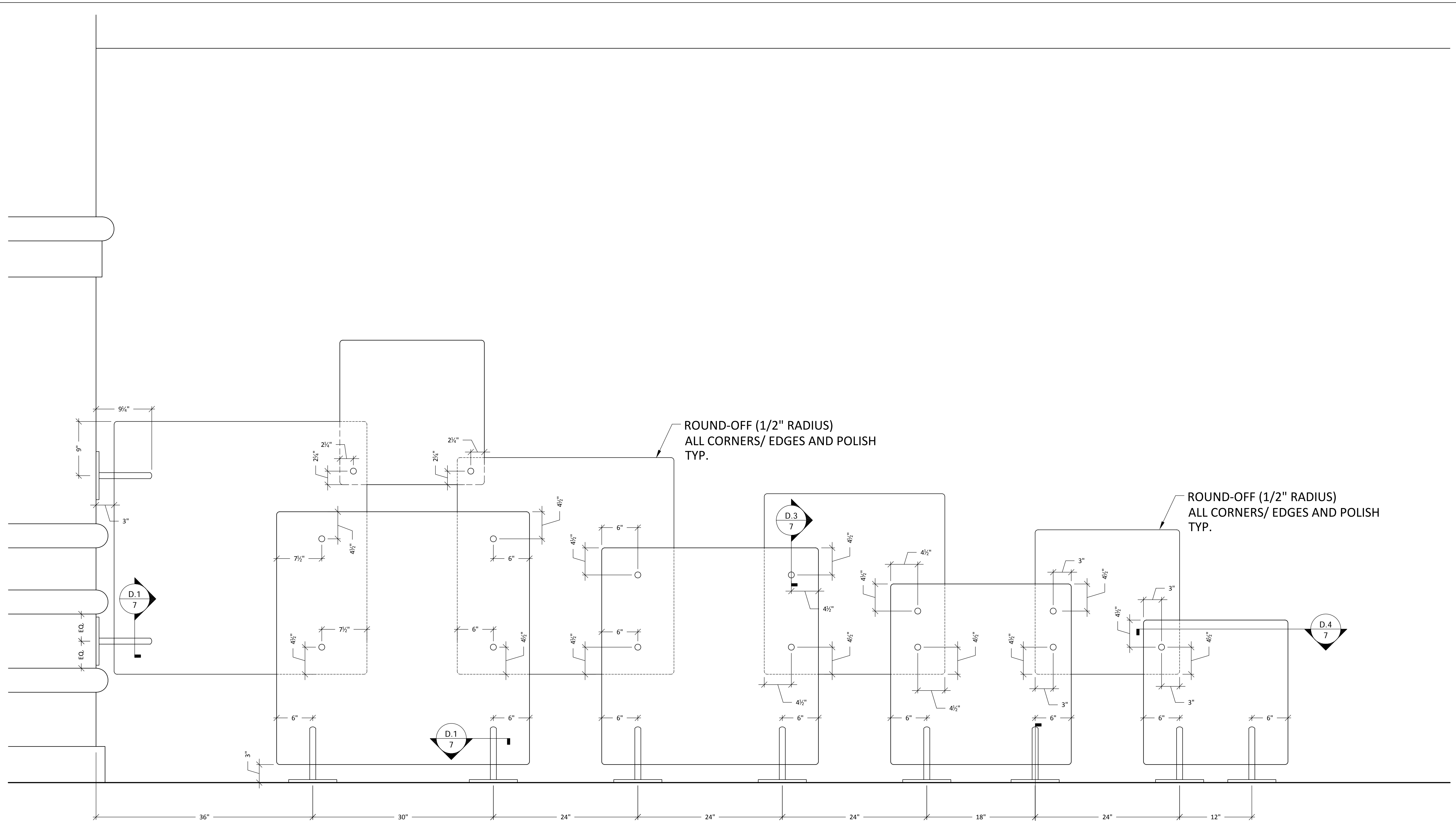

(A/B) MOUNTING HARDWARE LAYOUT
Scale: 1 1/2" = 12"
"B" ELEVATION IS MIRROR IMAGE

Note:
All Stainless Steel to have
bead blasted finish.

Drawn by: *Nino K.*

NO.	REVISION REASON	DATE
	PANEL SUPPORT BASE PLATE	NOV-10

Project: BOYLAN HALL CAFETERIA SCREENS
Date: 10-21-08
Job #:

Note:
All Stainless Steel to have
bead blasted finish.

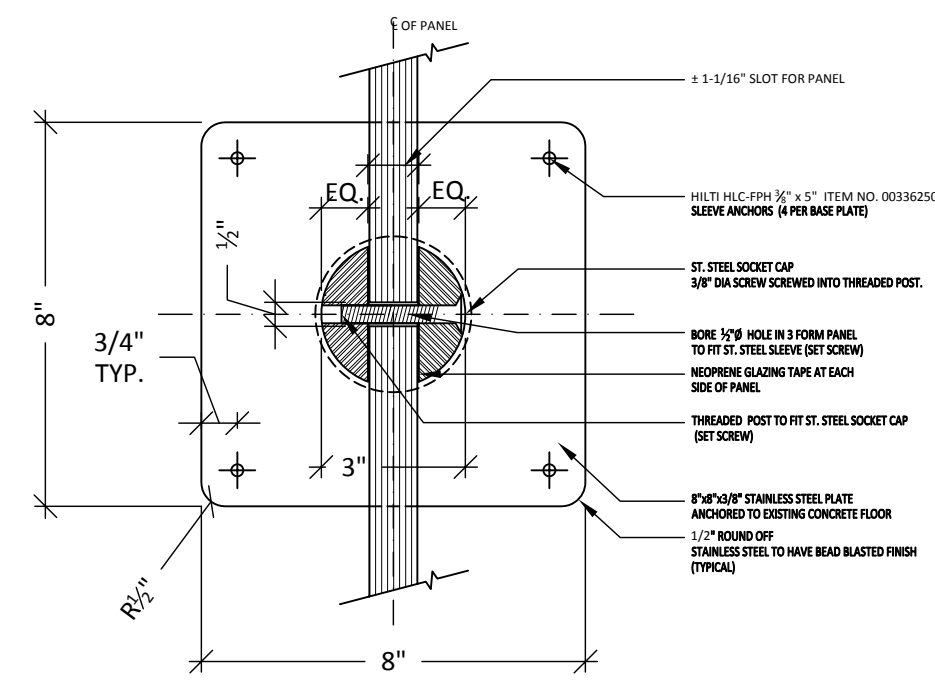

D.1 DETAIL- @ PANEL SUPPORT BASE PLATE
Scale: 3" = 12"

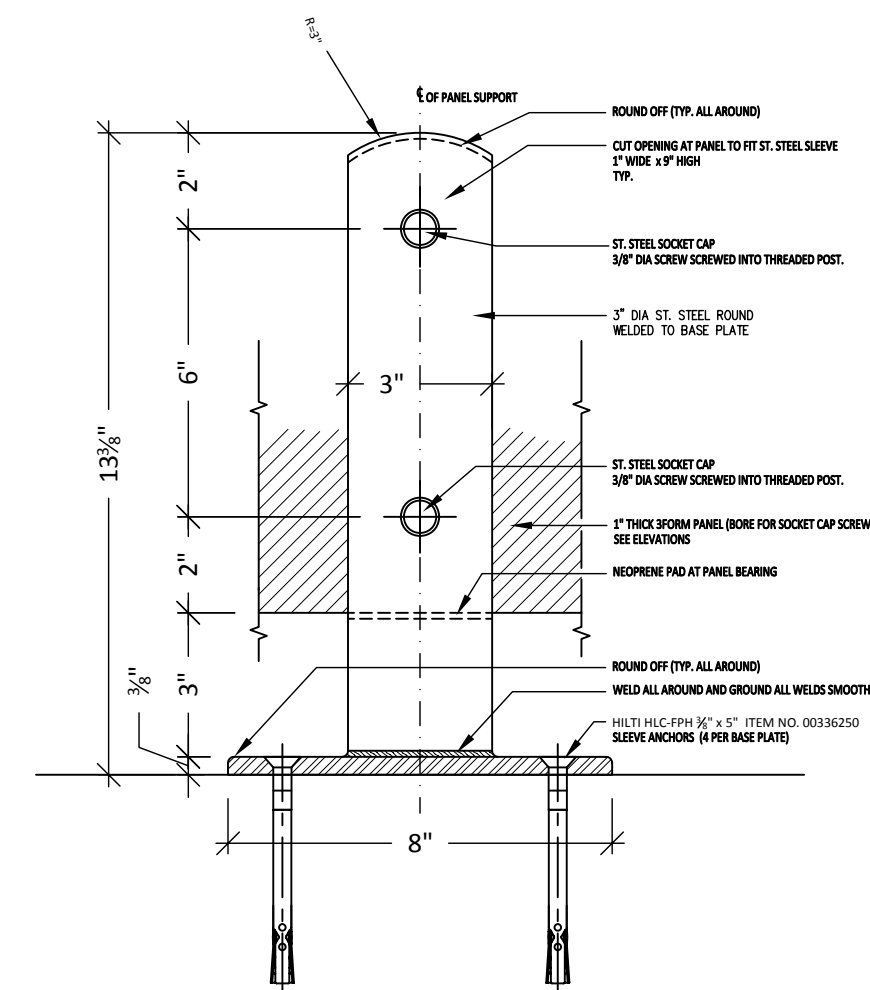

D.2 DETAIL- @ PANEL SUPPORT
Scale: 3" = 12"

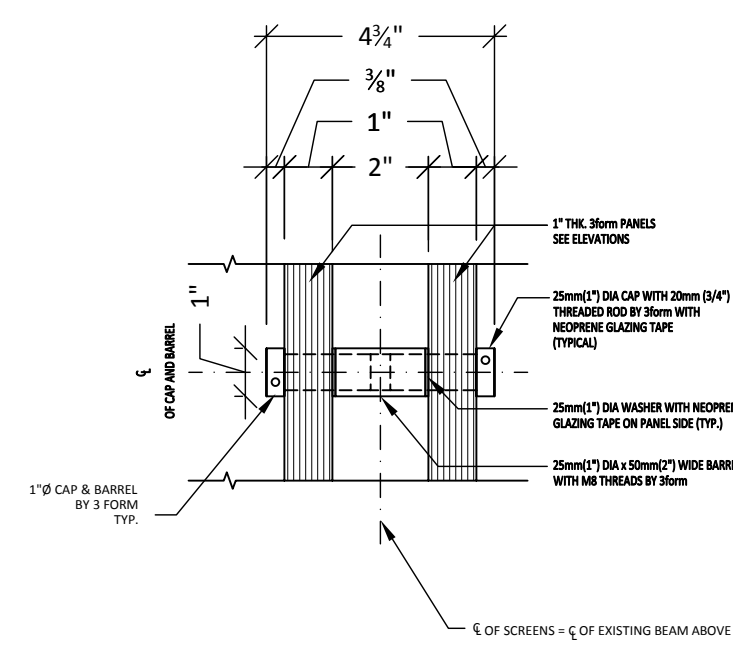

D.3 DETAIL- @ CAP & BARREL PANEL SUPPORT
Scale: 3" = 12"

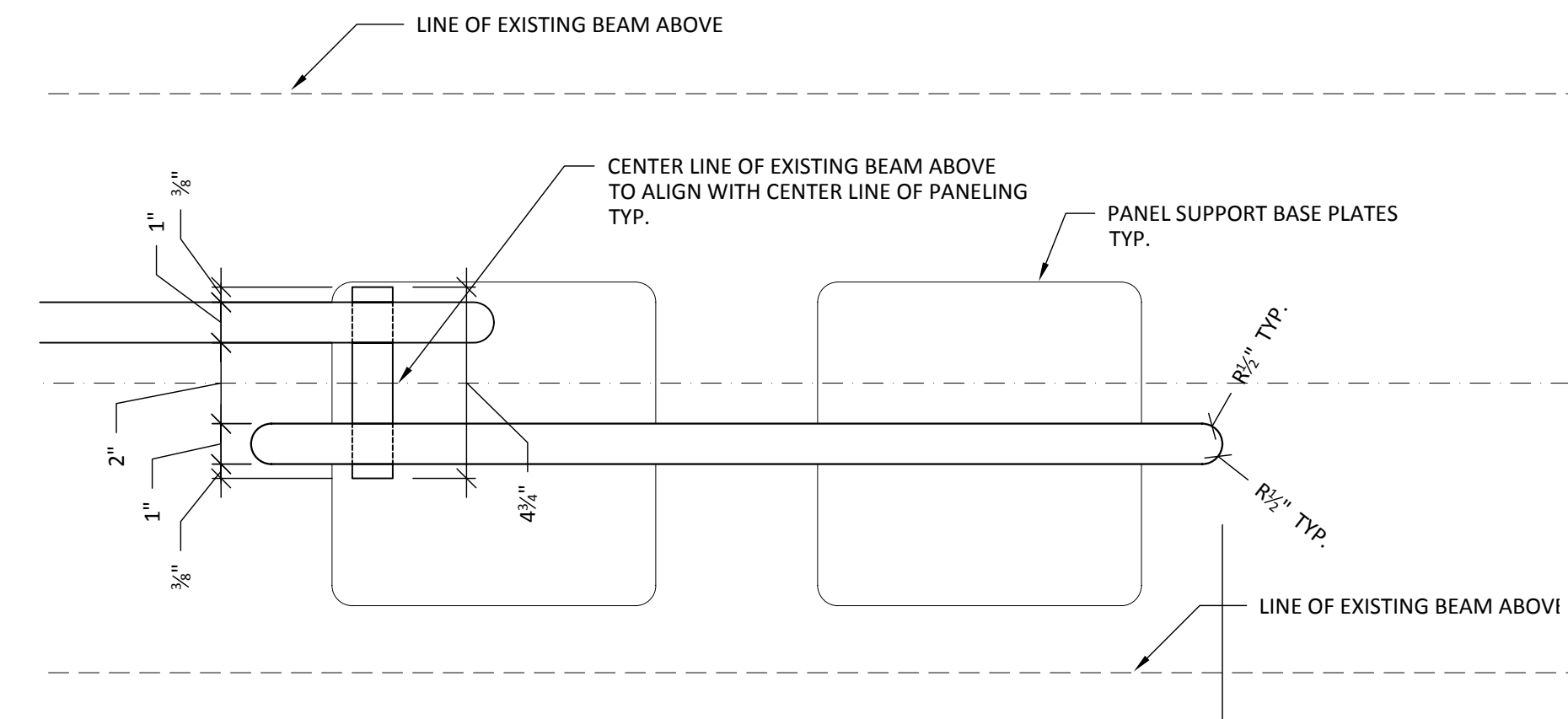

D.4 DETAIL- PANEL EDGE PROFILE & SPACING
Scale: 3" = 12"

3 FORM VARIA ECORESIN PANEL TEAK-OFF TABLE

PANEL DESIGNATION	QUANTITY TOTAL	PRODUCT NAME	PANEL COLOR	GAUGE	FRONT PANEL FINISH	BACK PANEL FINISH	PANEL SIZES
A	8	SOLO #SO-69410.3	Bliss x1 (1) + Bliss x2 (2)	1 Inch	Sandstone	Sandstotne	(2)24"x24" (2)30"x30" (2)36"x36" (2)42"x42"
B	4	SOLO #SO-69410.1	Sassy x1 (7)	1 Inch	Sandstone	Sandstotne	(1)24"x24" (1)30"x30" (1)36"x36" (1)42"x42"
C	N/A/	SOLO #SO-69410.5	Oj x1 (11) + Canary x1 (9)	1 Inch	Sandstone	Sandstotne	
D	4	SOLO #SO-69410.4	Canary x2 (10)	1 Inch	Sandstone	Sandstotne	(1)24"x24" (1)30"x30" (1)36"x36" (1)42"x42"
E	2	SOLO #SO-69410.2	Vapor x1 (45)	1 Inch	Patina	Sandstotne	(2)24"x24"

Drawn by: Nino K.

NO.	REVISION/REASON	DATE
	PANEL SUPPORT BASE PLATE	REV. 01

Project:	BOYLAN HALL CAFETERIA SCREENS
Date:	10-21-08
Job #:	